

BACHELORETTE ♦ HOUSE

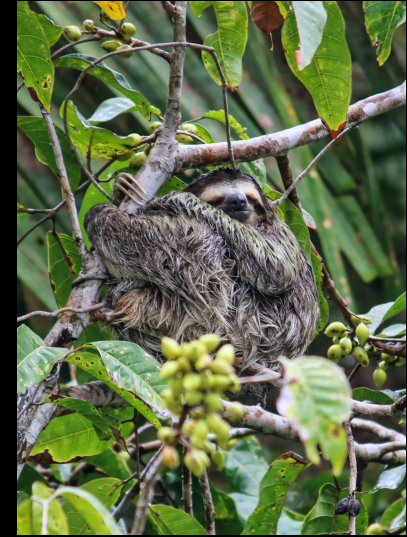

NATURALEZA ♦ FELICIDAD ♦ DIVERSIÓN

VALLE DE ANTÓN | PANAMÁ | CONCEPTO FINAL

PROYECTOS
LA LLAR





El origen de Proyectos La Llar tiene como objetivo principal fomentar la excelencia en la arquitectura y mejorar la relación entre arquitectos y clientes interesados en construir su vivienda. Reconociendo la importancia de seleccionar al arquitecto adecuado para llevar a cabo una inversión tan significativa como la construcción de una casa, Proyectos La Llar ha establecido una cuidadosa selección de arquitectos, tanto a nivel nacional como internacional. Estos arquitectos compiten en concursos privados organizados por Proyectos La Llar, donde los clientes tienen la oportunidad de elegir entre varios proyectos diseñados especialmente para su parcela, adaptados a su presupuesto, preferencias y necesidades.

Índice

4. Colorimetría y texturas exterior
5. Colorimetría interior
6. Material en interior
7. Acceso exterior
8. Acceso interior
9. Lobby
10. Volumetría y acceso a la casa
12. Arquitectura
14. Propuestas de distribución
16. Material exterior
17. Vegetación
18. Cancelería
19. Piscina
21. Concepto interior
25. Espacios de uso múltiple

_ COLORIMETRÍA Y TEXTURAS EN EXTERIOR _

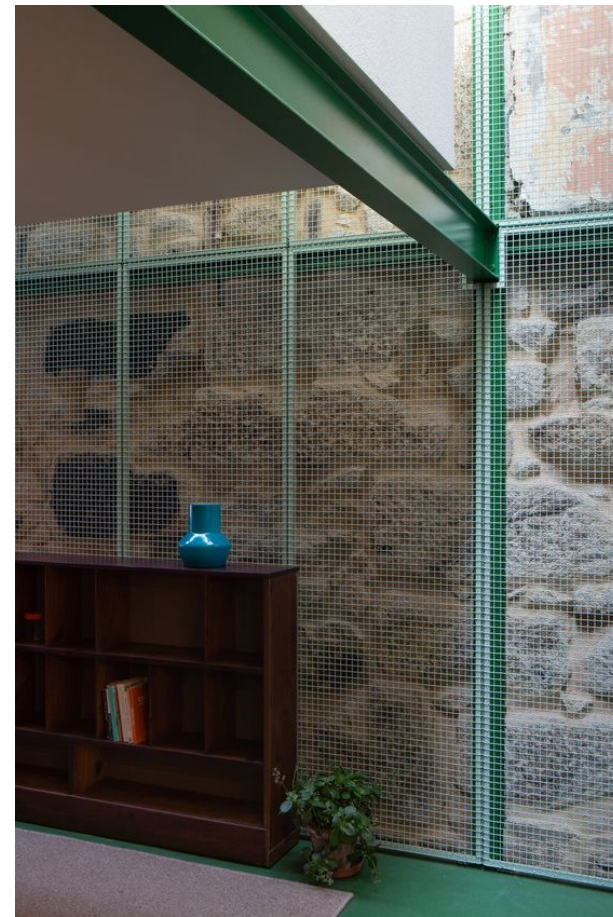

_ COLORIMETRÍA INTERIOR _

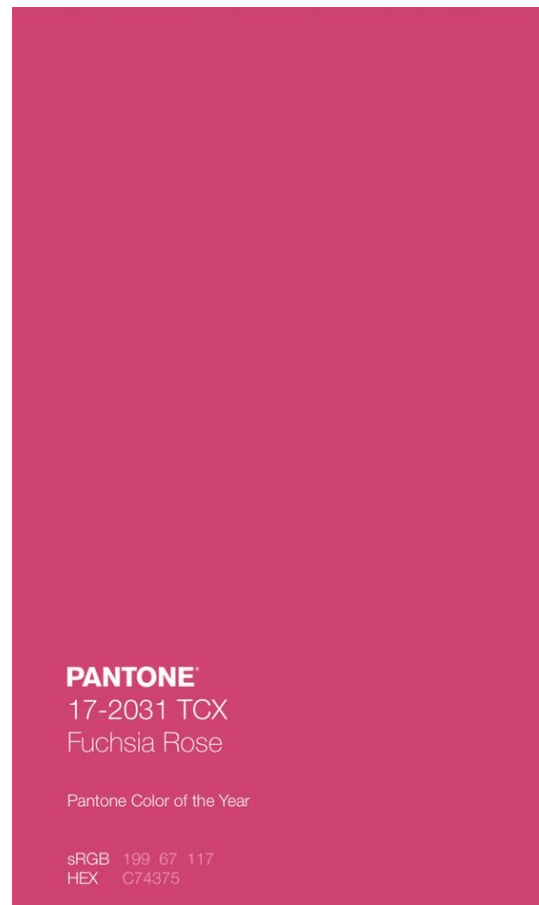

_ MATERIALIDAD EN INTERIOR _



_ ACCESO EXTERIOR _



_ ACCESO INTERIOR _



_ MOTOR LOBBY _



_ PROPUESTA DE VOLUMETRÍA Y ACCESO DE LA CASA _



_ VOLUMETRÍA ARQUITECTÓNICA Y ZONIFICACIÓN _



_ ARQUITECTURA _

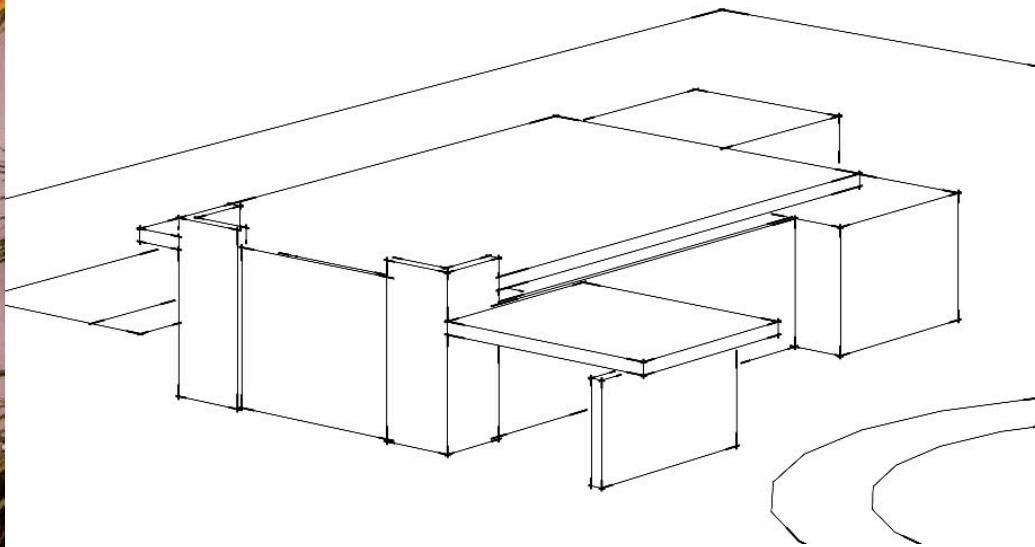

_ ARQUITECTURA _

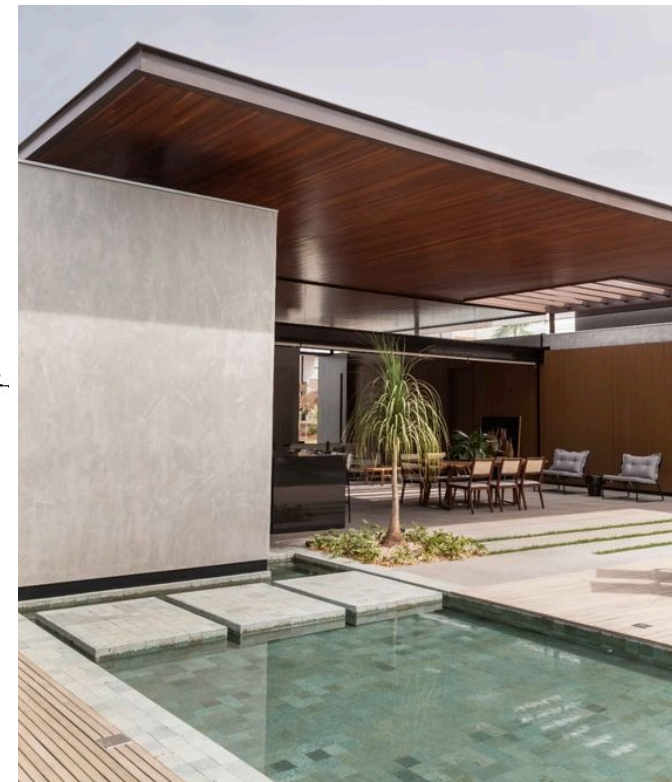
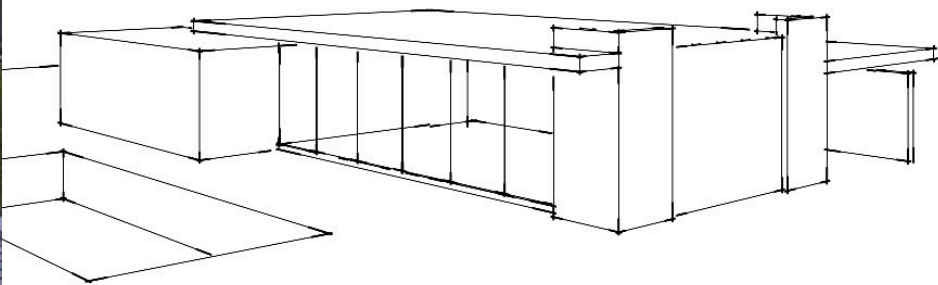

_ PROPUESTA DE ZONIFICACIÓN 1 _

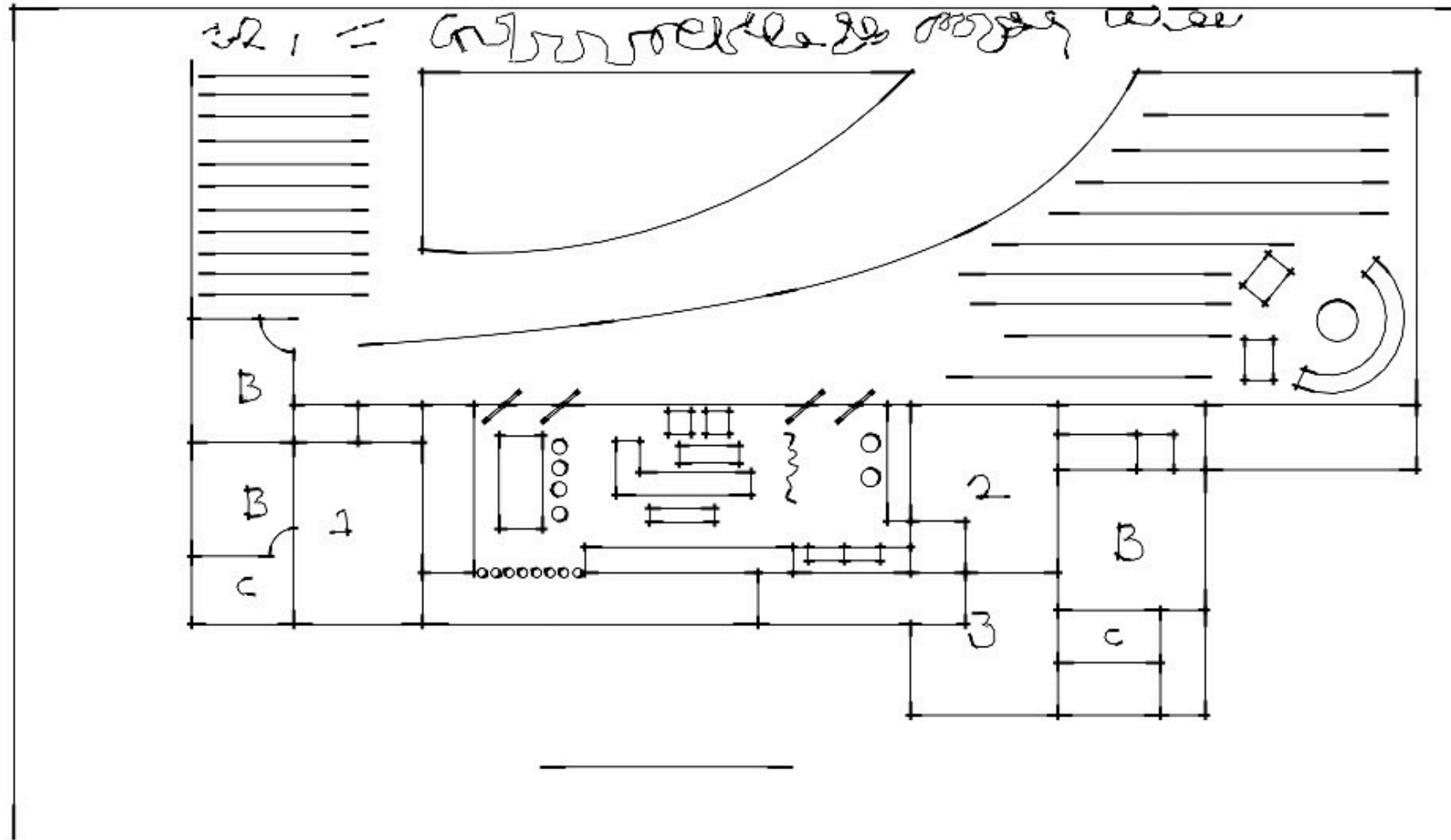

_ PROPUESTA DE ZONIFICACIÓN 2 _

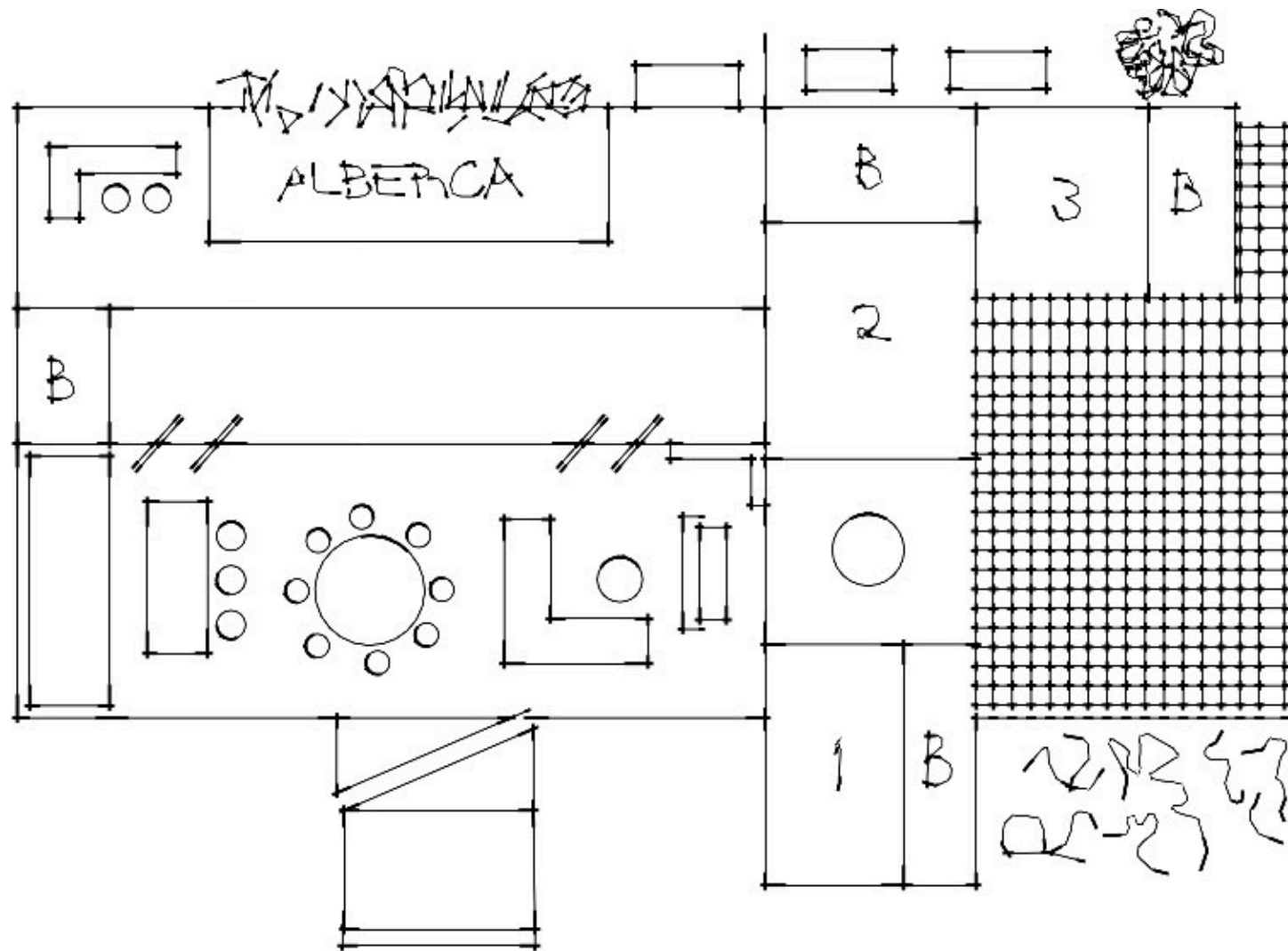

_ MATEREALIDAD EXTERIOR _



_ ANDADORES Y VEGETACIÓN _



_ CANCELERÍA CON COLOR LLAMATIVO _



_ CONCEPTO DE PISCINA Y ZONA
EXTERIOR _



_ CONCEPTO DE ALBERCA _



_ CONCEPTO DE INTERIOR _



_ DIVISION ENTRE ÁREAS _

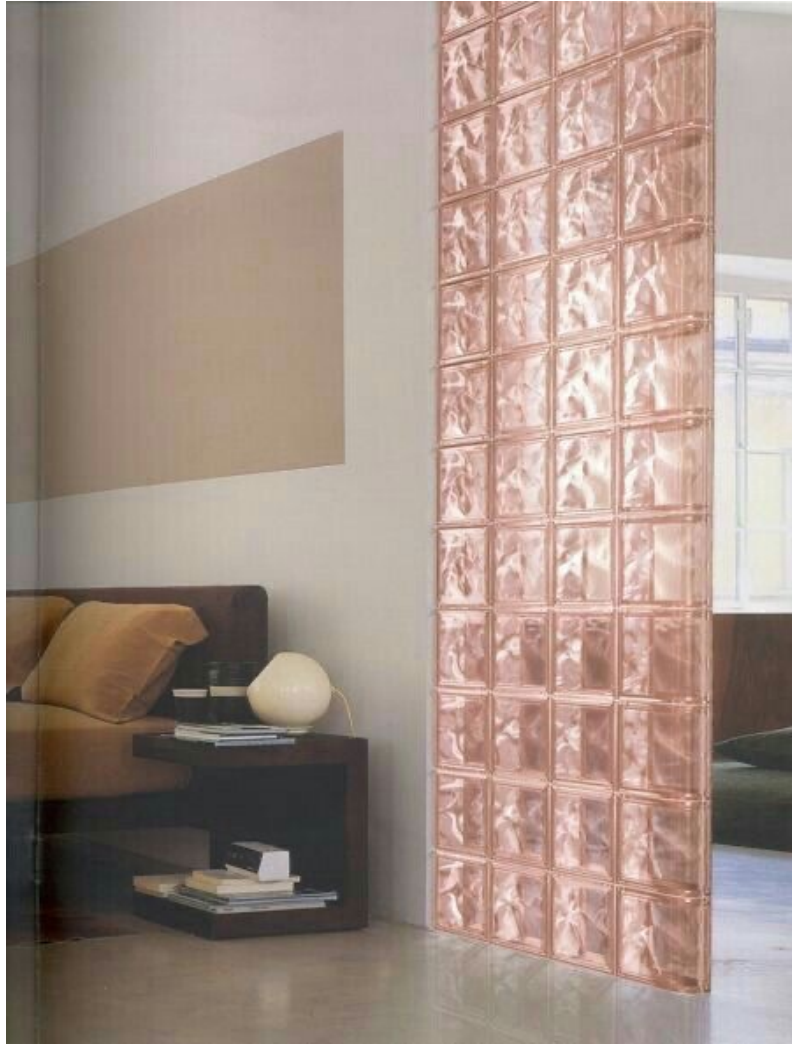

_ CONCEPTO DE HABITACIONES _



_ CONCEPTO DE ZONAS COMUNES

EXTERIORES

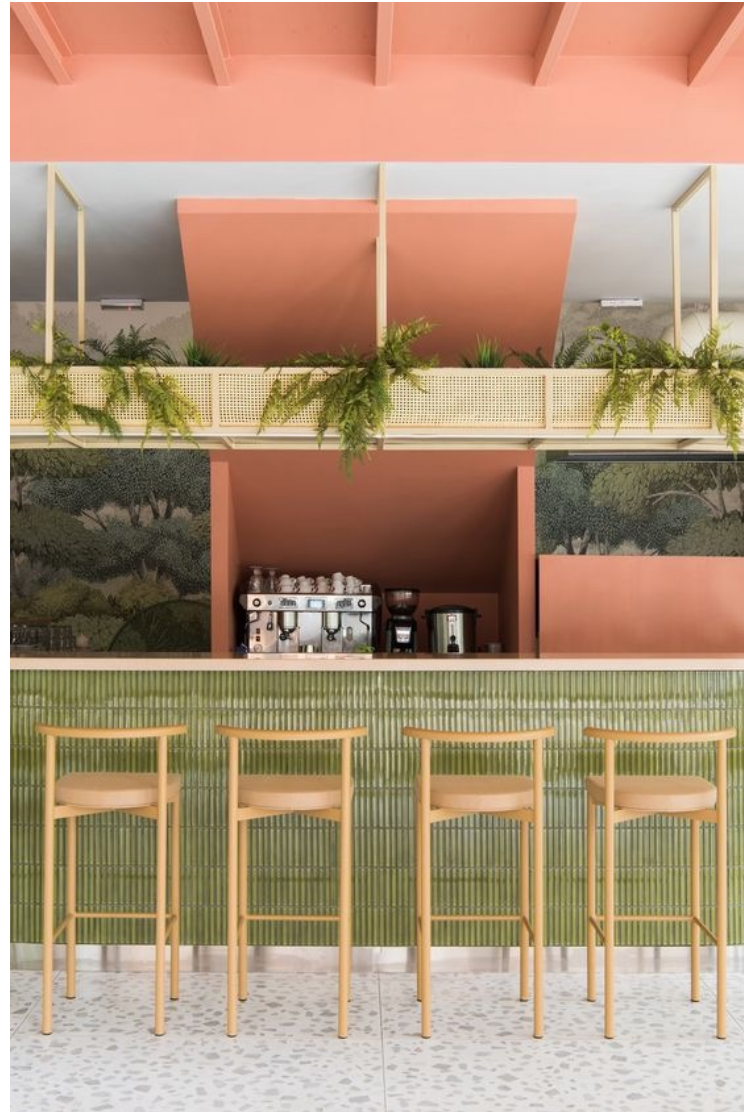

_ ESPACIO DE USOS MÚLTIPLES _

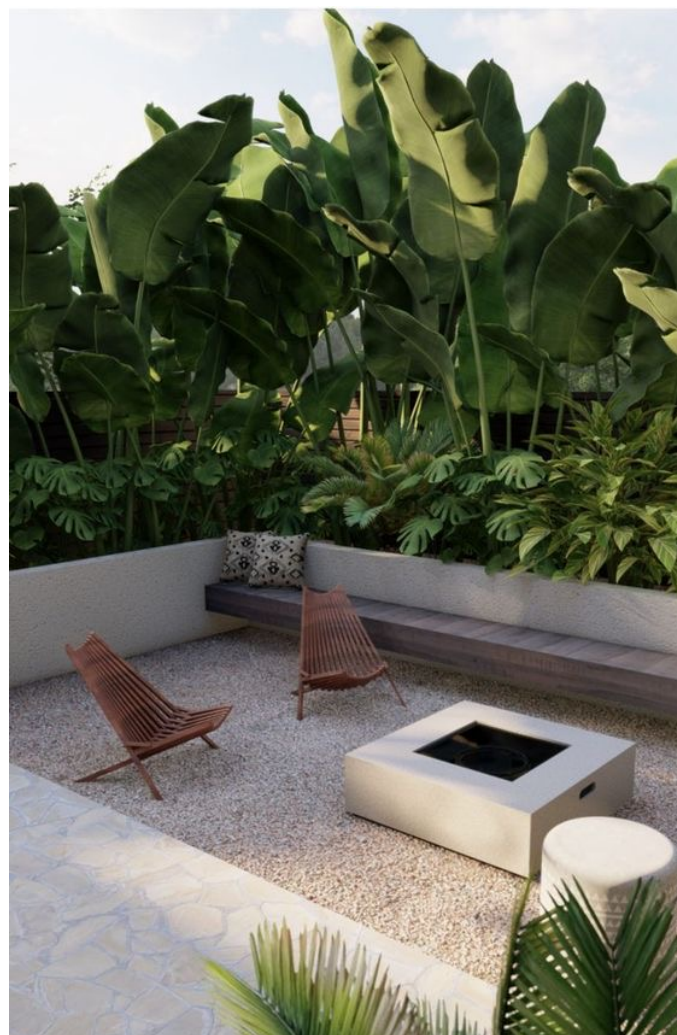

ÁREA PARA AMQUILLAJE

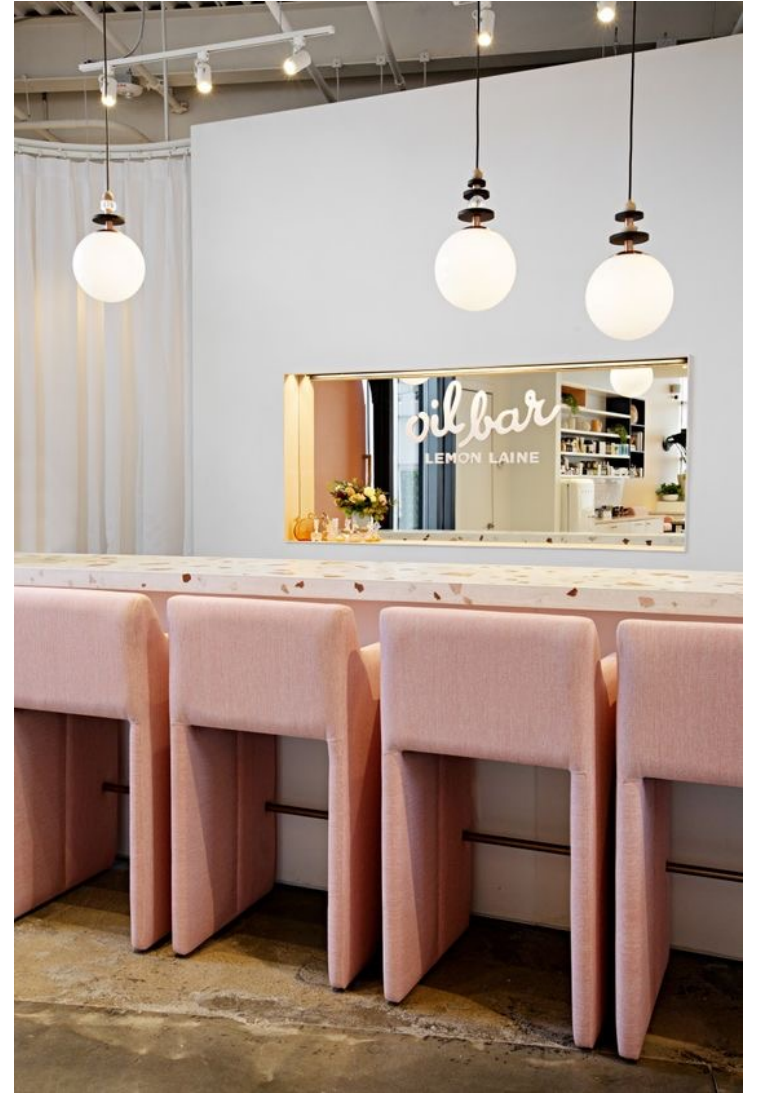

_ PISCINA Y ESPACIO LÚDICO _



_ DETALLES DE TERAZA _

